



SAM PuttLab

...the reference in putt training

SAM PuttLab Extended Reports

Project

Name: shortgame bootcamp
Description:

Player

Name: Nørgaard, Søren
Born: -
Hand: right
Handicap: -
Playing since: -

Session

Name: Measurement - 09.06.2018
Description:
Date: 09.06.2018

File

Name: Measurement - 09.06.2018(..
Description:
Date: 09.06.2018
Putts: 5

Tendency

72.2%

Timing

88.6%

Consistency

46.5%

Overall Rating

63.4%

Aiming Report

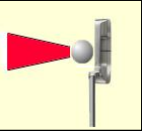

Face Aim

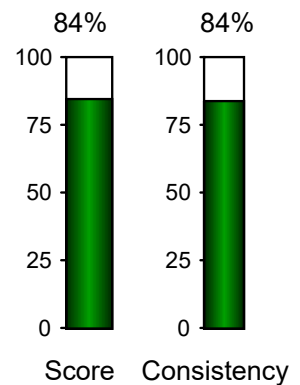
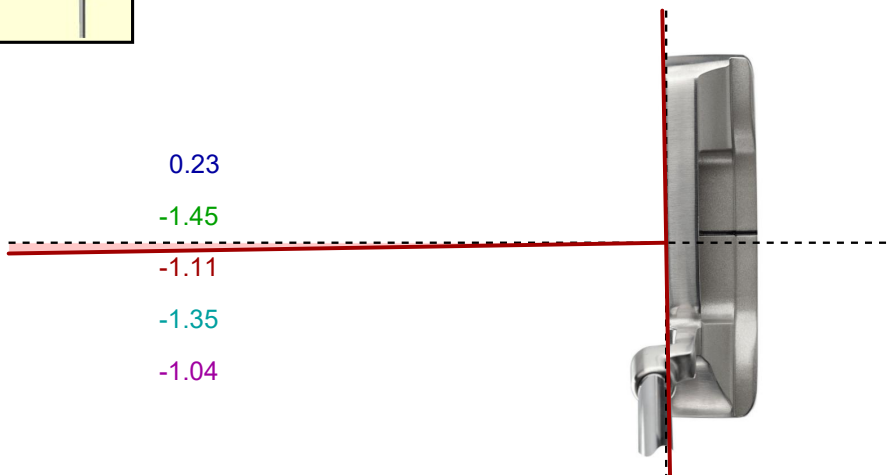

0.9° closed

Face at adress

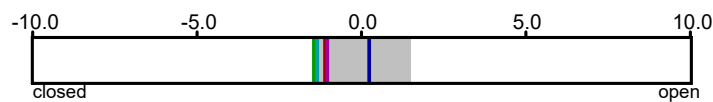

0.9° closed

Face change

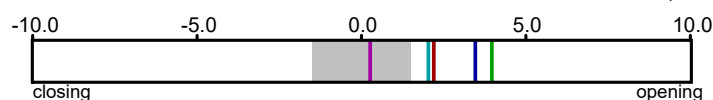

2.4° opening



SAM PuttLab

...the reference in putt training

Project: shortgame bootcamp
 Player: Nørgaard, Søren
 File: Measurement - 09.06.2018(..
 Date: 09.06.2018

Direction

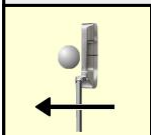

Face at impact

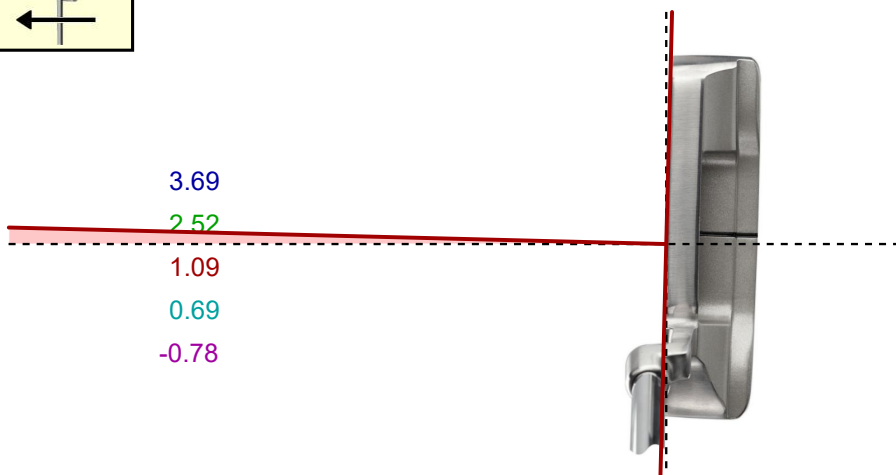

1.4° open

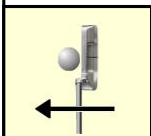
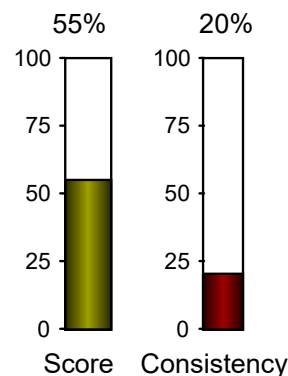

Path at impact

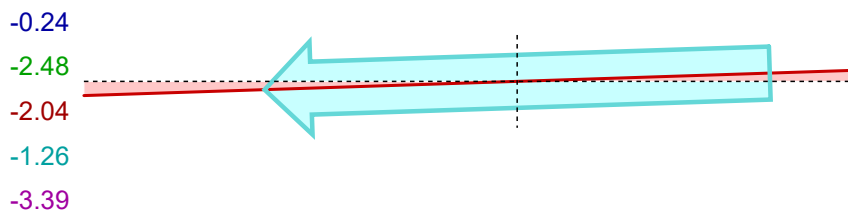

1.9° left

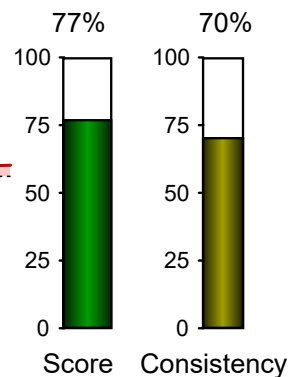

Face at Impact

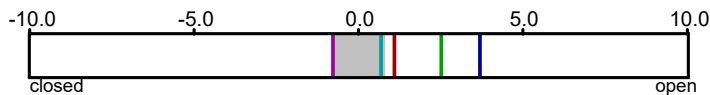

1.4° open

Path direction impact

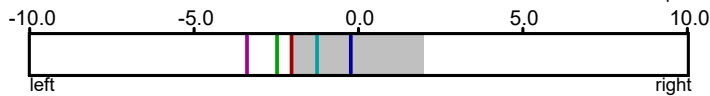

1.9° left

Face on path impact

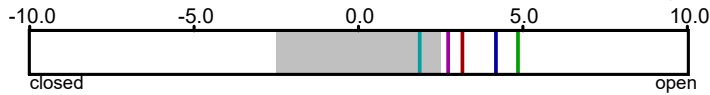

3.4° open

Ball direction

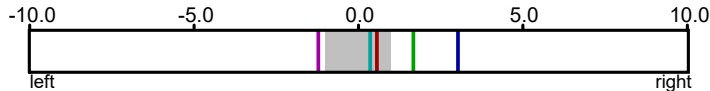

0.9° right



SAM PuttLab

...the reference in putt training

Project: shortgame bootcamp
Player: Nørgaard, Søren
File: Measurement - 09.06.2018(..
Date: 09.06.2018

Path & Spot

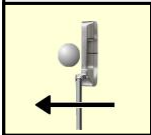

Top view

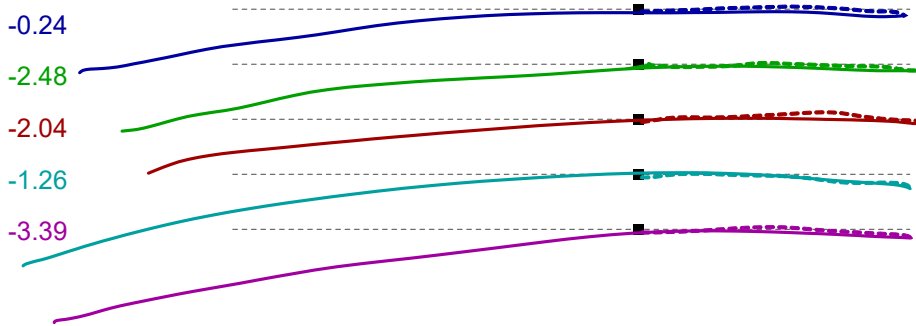

100 mm

1.9° left

Impact spot

-1.04
3.82
4.89
3.49
3.16

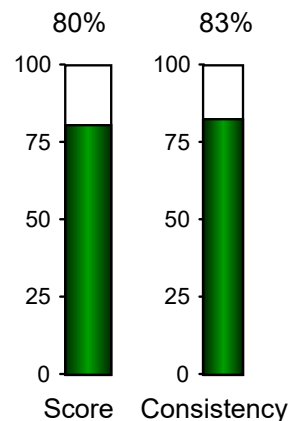
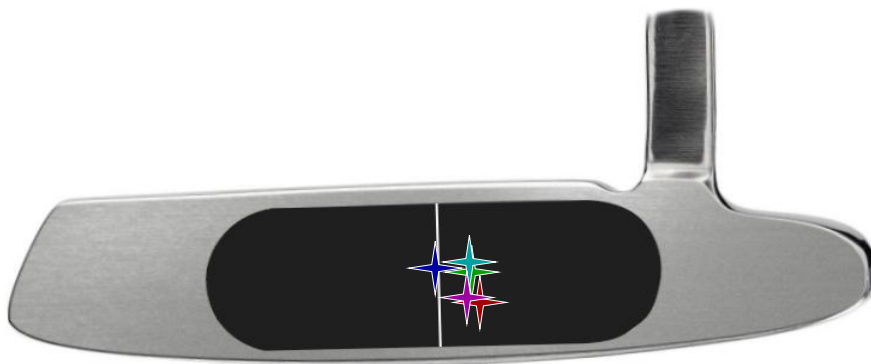

Spot: 2.9 mm heel

Lie angle: 1.4 ° toe down

Backswing Ratio

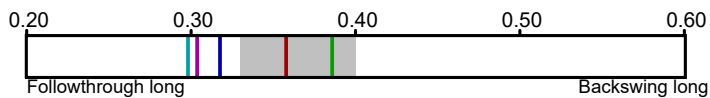

0.33

Impact spot

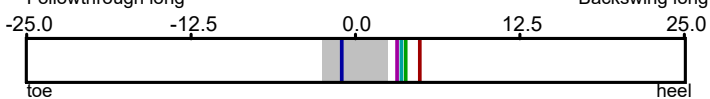

2.9 mm heel

Height on Face

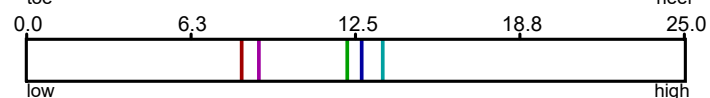

11.1 mm



SAM PuttLab

...the reference in
putt training

Project: shortgame bootcamp
Player: Nørgaard, Søren
File: Measurement - 09.06.2018(..
Date: 09.06.2018

Loft & Rise

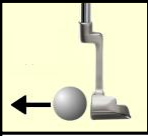

Side view

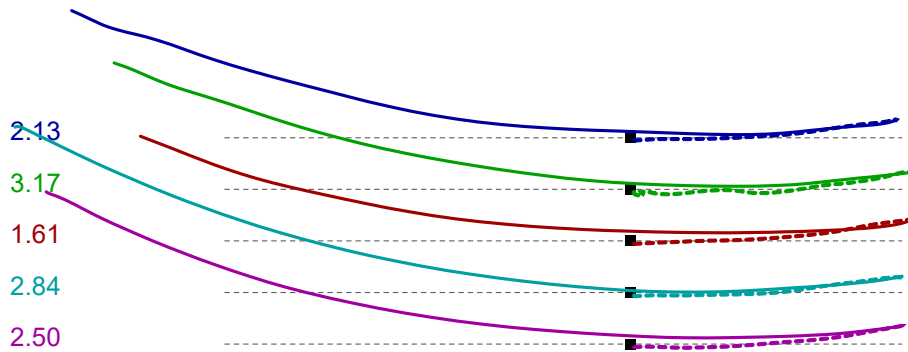

100 mm

Rise at impact: 2.4° up

Launch & Spin

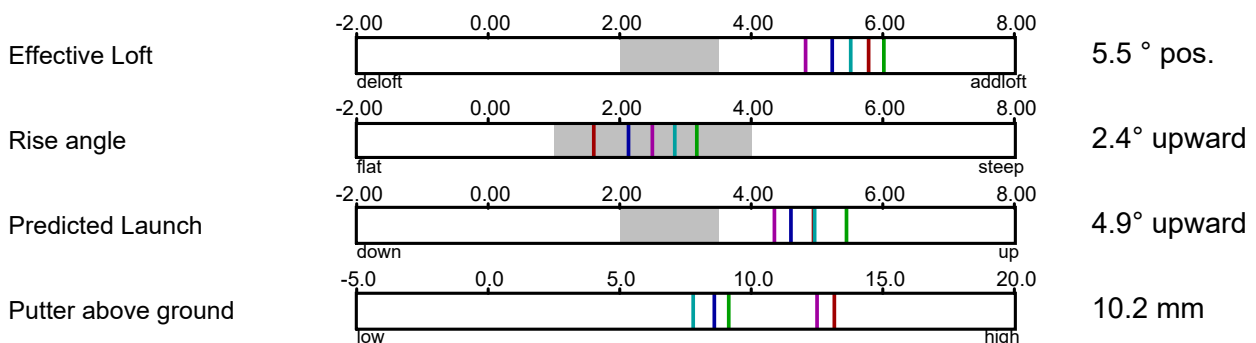
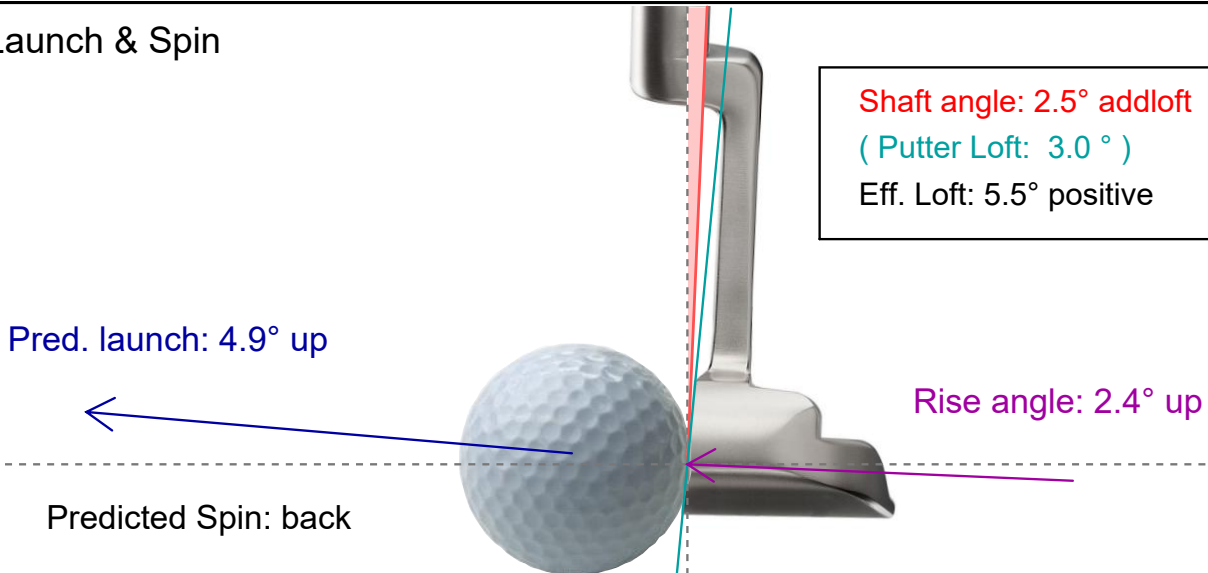



Project: shortgame bootcamp
 Player: Nørgaard, Søren
 File: Measurement - 09.06.2018(..
 Date: 09.06.2018

Face Rotation

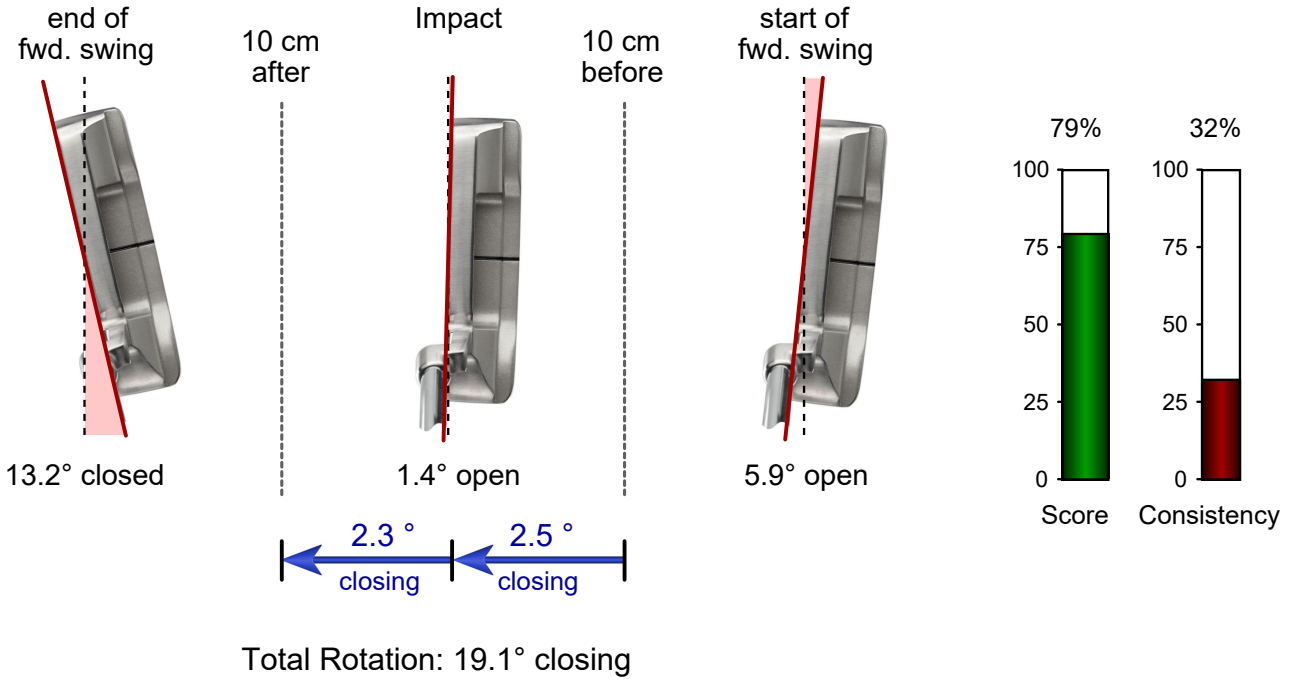

Face Angle

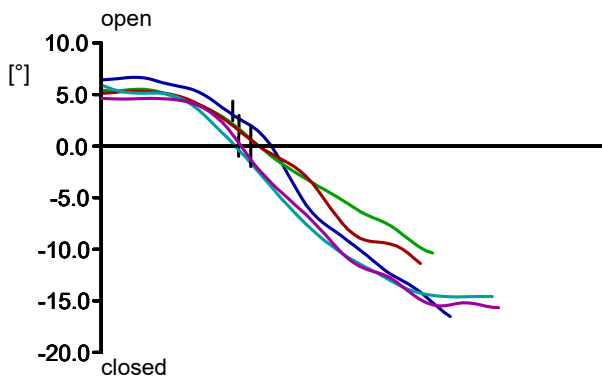

Rotation

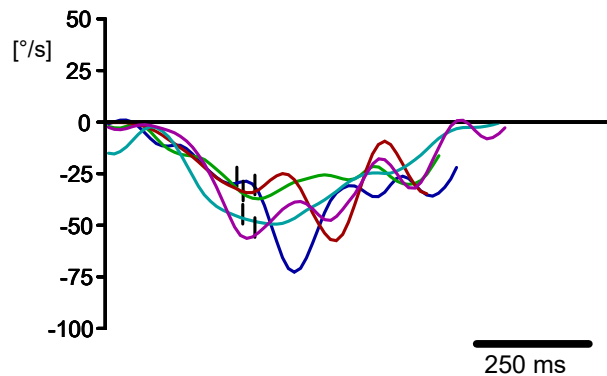

Before Impact (10 cm)

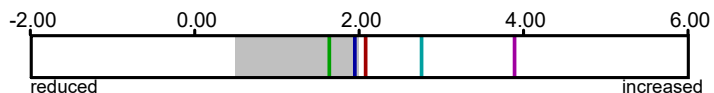

2.5°

After Impact (10 cm)

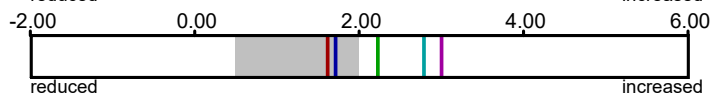

2.3°

Rotation rate at Impact

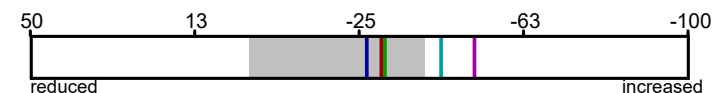

36.5°/s closing

Rotation rel. to path

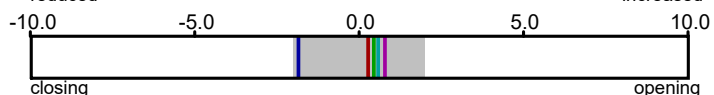

0.0° opening



SAM PuttLab

...the reference in putt training

Project: shortgame bootcamp
 Player: Nørgaard, Søren
 File: Measurement - 09.06.2018(..
 Date: 09.06.2018

Movement Dynamics

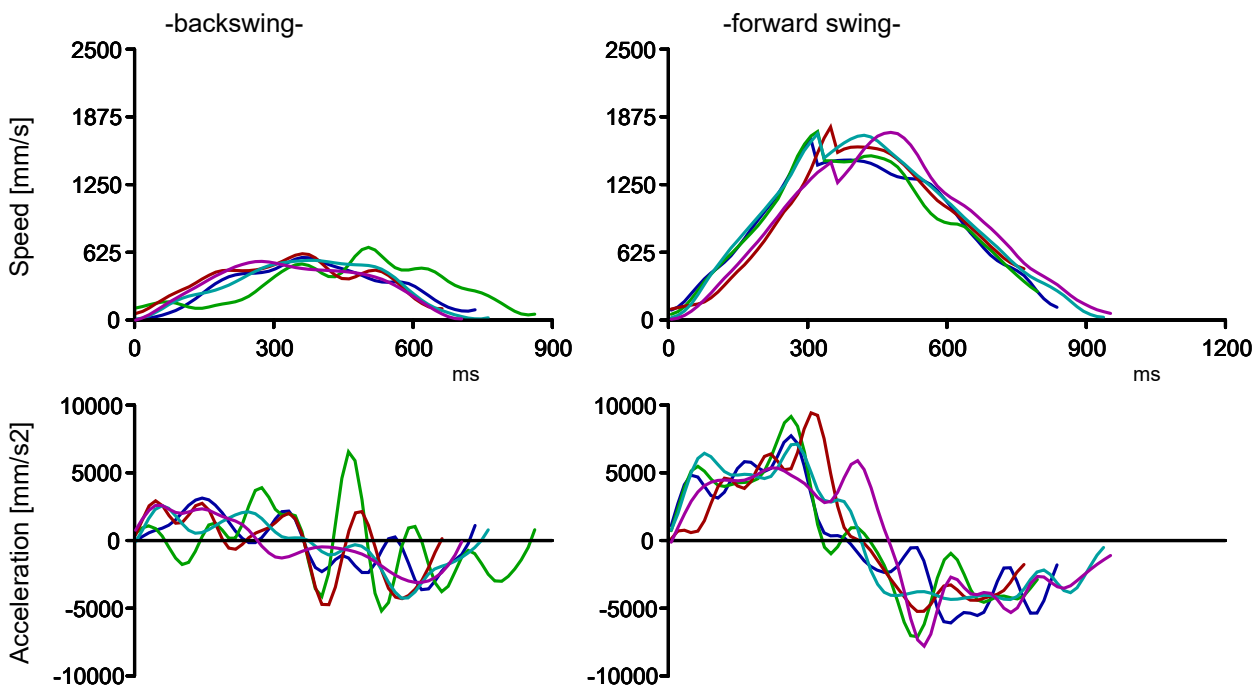

Timing

